

bartolini  
PICKUPS AND ELECTRONICS

New !



ZBS and PBF  
Guitar  
Pickups

Catalog 2002

# GUITAR PICKUPS

J5 jazz guitar shape

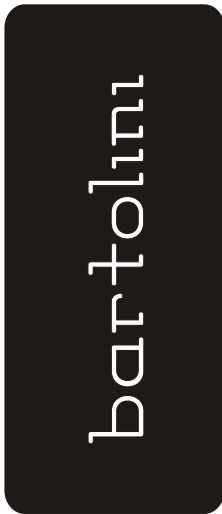

standard Strat shape



standard humbucker shape



## ZBS Humbuckers

- ZBS-50 sweet and clear
- ZBS-60 bright with hot mids
- ZBS-70 hot and nasty
- ZBS-75 a very interesting pickup
- ZBS-80 raw overdrive power

## PBF Humbuckers

- PBF-49 vintage neck humbucker
- PBF-51 vintage bridge humbucker
- PBF-55 vintage bridge humbucker - brighter
- PBF-57 special jazz humbucker
- PBF-77 industrial strength

## Humbuckers

- V92C-N very bright and clear neck HumBucker
- V92C-B warmer HB for neck or bright bridge
- V94-D deeper HB for bridge - near PAF output
- E92C-B Active V92C-B / coil cut / high output + boost
- 1C unequal coil HB / clear warmth
- 1CTA equal coil / unequal response / high clarity
- TXE Active only for single HB jazz guitar / UltraLowNoise
- V88-C bright, glassy PAF level HB for neck
- V88-D deep tone bridge match to V88-C
- 1D-01 neck side of "Grunge Pair" - very good mids
- 1D-03 bridge side of "Grunge Pair" - deep, raw power

## Strat\* size

- V88S - N or S very clear, glassy, near Vintage tone single coil
- 3XQ - N or S very clear, smooth, near Vintage tone sng. coil
- 3X - N or S clear, smooth, full range single coil
- 3XR - N or S deeper tone, high power, bridge pos. sng. coil
- 3S - N or S tapped single coil for deep/bright choice
- 3D-01 N or S single coil of 1D-01 "Grunge" neck humbucker

## ZBSC Single coils

- ZBSC-60 the best single coil tone we have heard yet

## Jazz Guitar (Johnny Smith type)

- 5J smooth, clear dual coil - end of fingerboard bracket
- 5JNB smooth, clear dual coil without mounting bracket

## Large Humbucker for 7 string guitar

- 492C-B 7 string version of V92C-B
- 4CTA 7 string version of 1C-TA
- 494-D 7 string version of V92-D
- 4D-01 7 string version of 1D-01
- 4D-01 7 string version of 1D-03
- E494D Active - 7 string version of E92C-B

### Soapbar (P90) shape

SBC	Soapbar shape version of 1C
SB88-C	Soapbar shape version of V88C
SB88-D	Soapbar shape version of V88-D
SB88K-N	Soapbar shape bright version of V88-C
SB88K-B	Soapbar shape bright version of V88-D

Q-90	P-90 tone, twice the power, no hum
Q-90B	Fatter version on the Q-90

### Active Strat Systems (prewired)

System 111	equal stacked coils / vint. tone / high output + boost
System 111B	unequal stack coils / vint. tone / high output + boost
System 112	SSH / coil cut // vint. tone / high output + boost

### Acoustic Guitar (soundhole mounting)

3A	soundhole mount single coil for steel string guitar
3AV	soundhole mount stacked coil for steel string guitar
E3AV	soundhole mount active pickup for steel string guitar

## ZBS Series

For the last 2 years it has been our pleasure to collaborate with Ron Armstrong on the design of the ZBS guitar pickups. Ron was the man behind Star's Guitars in the late 70's. The Warp series preamps, Stardrive EQ, Slot-Tops pickups covers, Brass Mass and other bridges, and Excalibur guitars and basses stand to his credit. Our testing, R&D, and advanced technology have combined to yield tone and power beyond expectations. We are proud to bring to you these new designs as humbuckers, single coils and soapbars.

For maximum resonance and unmatched ability to "cut through" the most complex mixes, these pickups are available in ABS covers in black or white colors. They are also available in Nickel or Gold plated covers. The sound of these metal covered pickups is slightly mellower and fuller than those in ABS covers.

## PBF Series

For the last year and a half it has been our pleasure to collaborate with Ed Reynolds on the design of PBF guitar pickups. Ed was a builder of excellent guitars and basses and a top notch repairman in the Chicago area in the 70's and early 80's. He has continued his work in the Austin, Texas and now focuses exclusively on electric guitars. The tone of the PBF series pickups is a distillation of the best features of Vintage Humbucker tone. PBF's are more responsive and have better articulation, particularly on the lower strings. have captured all of the nuances that make other the others legendary, without any of their shortcomings, imbalance, or noise. Simply put, the PBF is the best humbucker that can be built. They are available in Nickel plated and Gold Plated covers. Their traditional, clean appearance will look equally at home in your '59 Paul, semi-hollowbody electric, or your Heavy Metal machine. For those who prefer the tone of uncovered pickups, they are available in ABS covers in black or white colors.

mini-humbucker shape



7 string humbucker shape

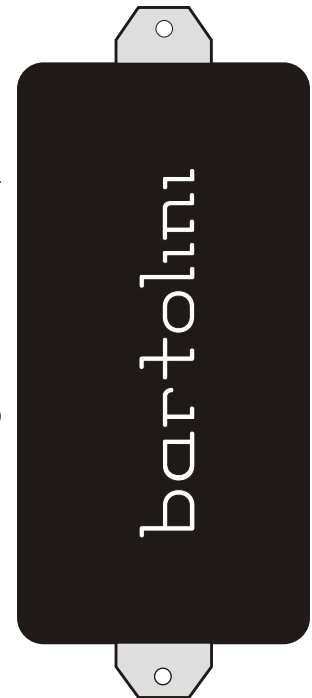

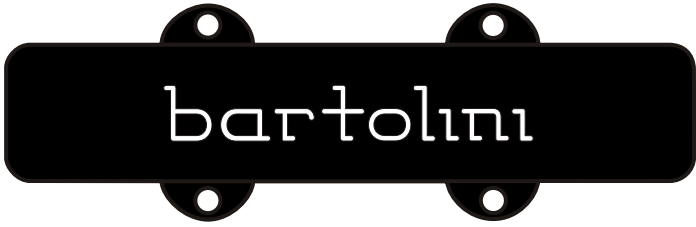

For Jazz Basses

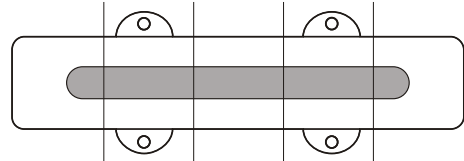
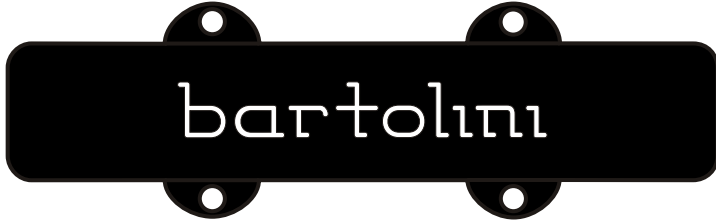

9SU - 4 string single coil

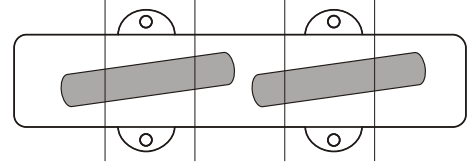

9J - 4 string split coil deeper tone  
9K - 4 string split coil brighter tone

MMC - 4 string dual coil - deep tone

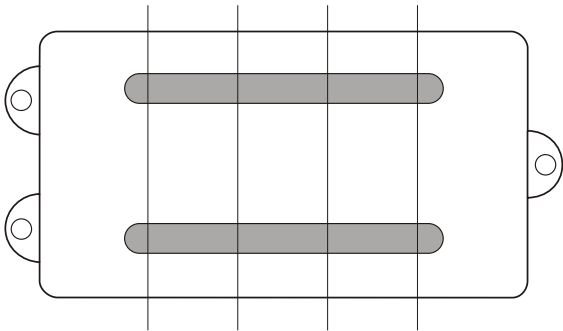

MMX - 4 string dual coil - bright tone



For Music Man Bases

72MM5E - 72mm 5 string tri-coil - deep tone

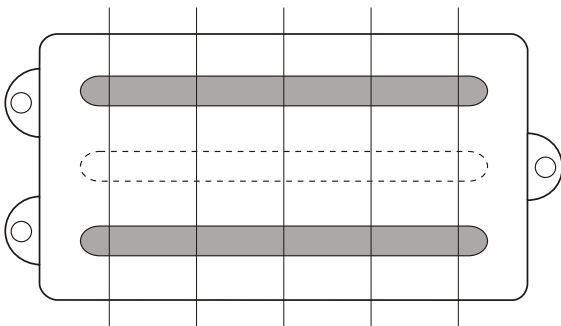

72MM5EK - 72mm 5 string tri-coil - bright tone

MME - 4 string triple coil - deep tone

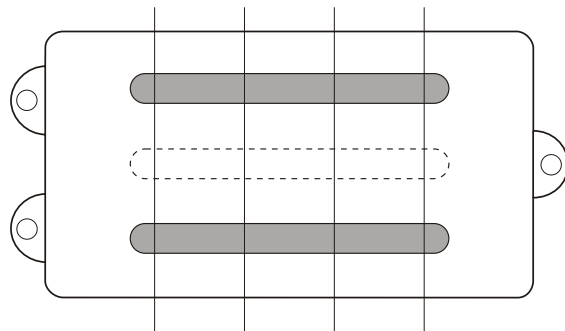

MME - 4 string triple coil - deep tone

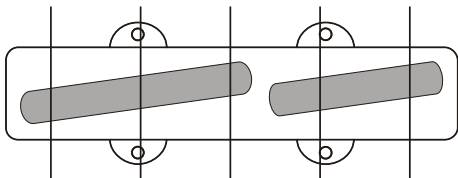

59J - 5 string split coil deeper tone  
59K - 5 string split coil brighter tone

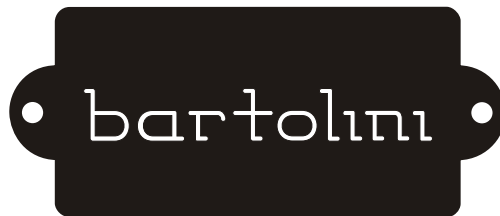

## For Precision Basses

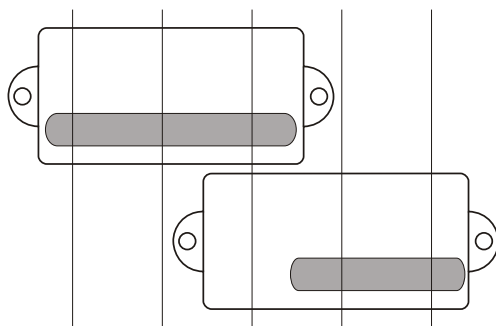

xx58S - 5 string deep tone  
xx58SU - 5 string brighter

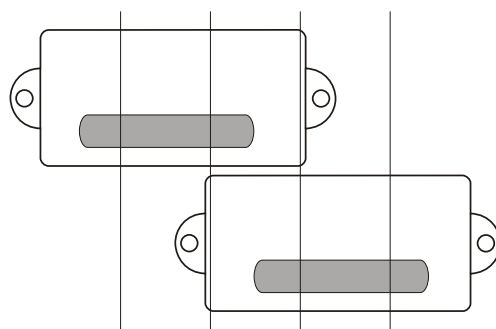

8S - 4 string deep tone  
8SU - 4 string brighter

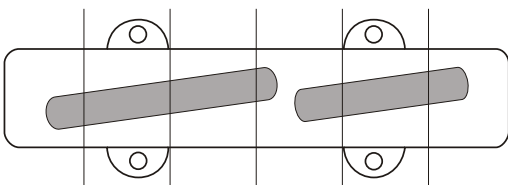

57J - 5 string split coil - deeper tone  
57K - 5 string split coil - brighter tone



## For American Std. Jazz Basses





## For 5 String Music Man Basses

72MV5E - 72mm 5 string triple coil - deep tone

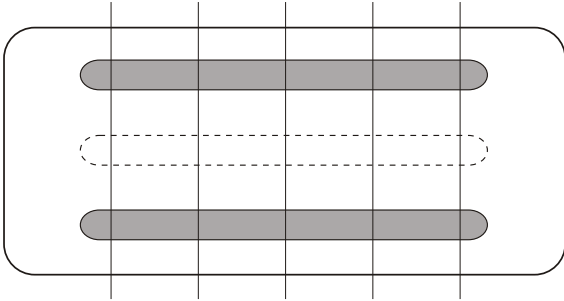

72MV5C - 72mm 5 string dual-coil - deep tone

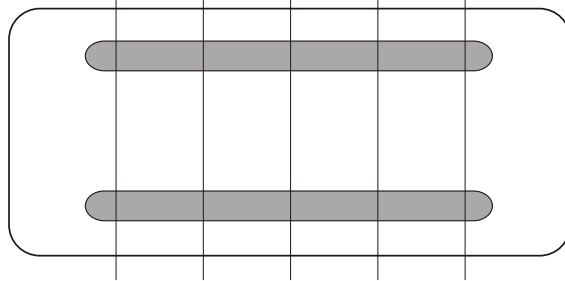

72MV5EK - 72mm 5 string triple coil - bright tone

72MV5CX - 72mm 5 string dual coil - bright tone



## For Rickenbacker 4001 Basses

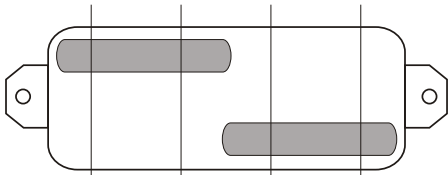

6RT - split coil - bass pickup

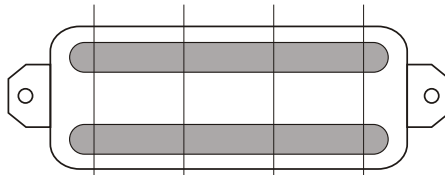

6RC - dual coil - treble pickup



Mute  
Compartment  
add-on

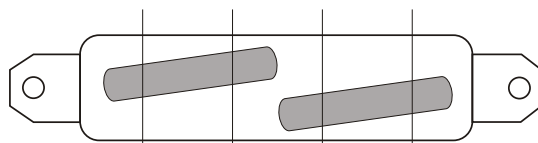

6JH - split coil - deep tone

SOAPBARS



bartolini

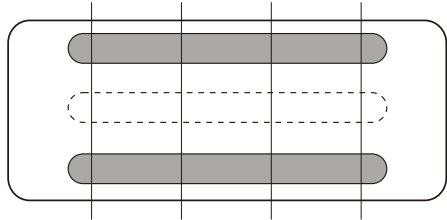

BB4E - triple coil - deeper  
BB4EX - triple coil - brighter

## BB

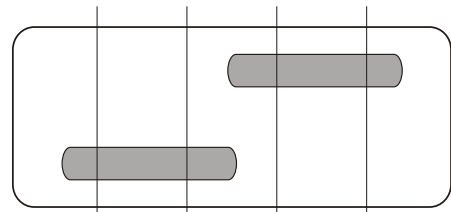

BB4M - split coil - deeper  
BB4T - split coil - brighter

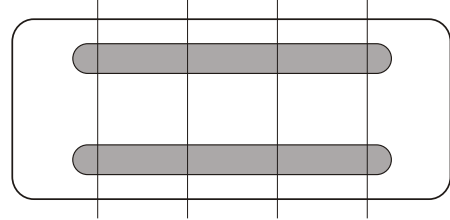

BB4C - dual coil - deeper  
BB4CX - dual coil - brighter



bartolini

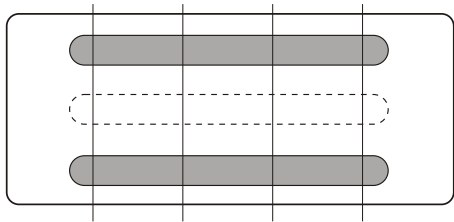

M34E - triple coil - deeper  
M34EX - triple coil - brighter

## M3

same shape  
as EMG35

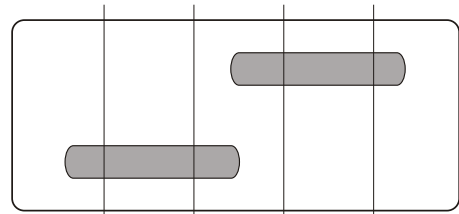

M34M - split coil - deeper  
M34T - split coil - brighter

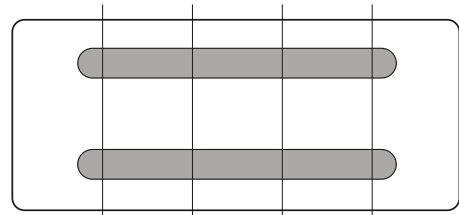

M34C - dual coil - deeper  
M34CX - dual coil - brighter



bartolini

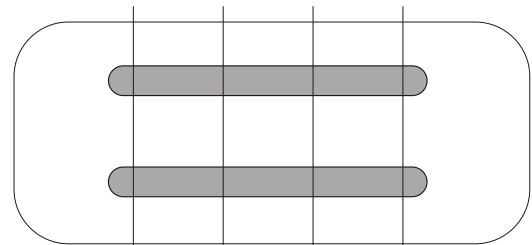

W4C - dual coil - deeper  
W4CX - dual coil - brighter

## W4

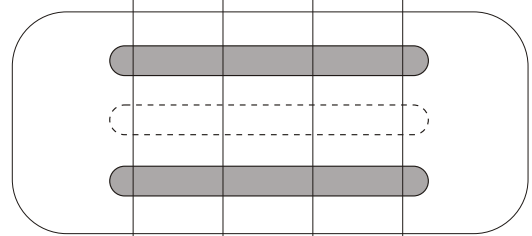

W4E - triple coil - deeper  
W4EX - triple coil - brighter





# X4

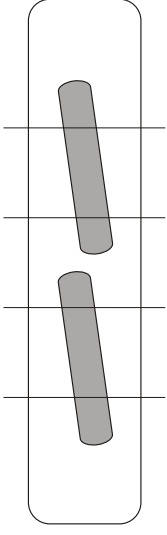

X44J - split coil - deeper tone

X44K - split coil - brighter tone

## 5 string soapbars

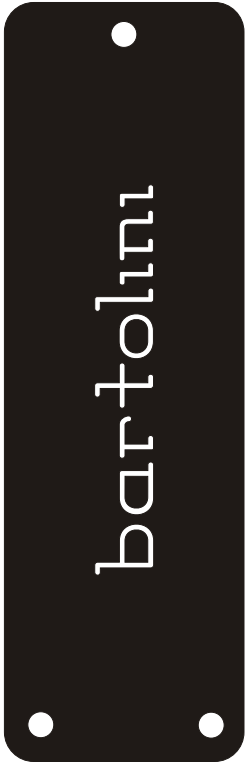

# BC

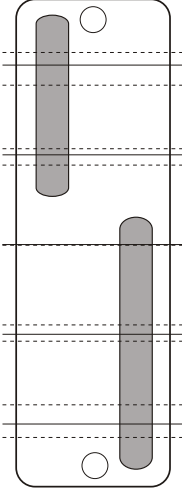

xxBC5M - 5 st. split coil - deeper

xxBC5T - 5 st. split coil - brighter

xxBC pickups will work with string widths from 64mm to 80mm if the fingerboard radius is greater than 14 inches (360mm)

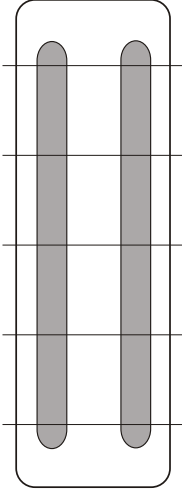

72BC5C - 72mm 5 st. dual coil - deeper

72BC5CX - 72mm 5 st. dual coil - brighter

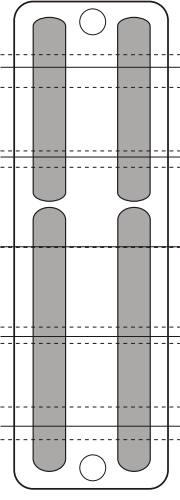

xxBC5C - 5 st. quad coil splittable - deeper

xxBC5CX - 5 st. quad coil splittable - brighter

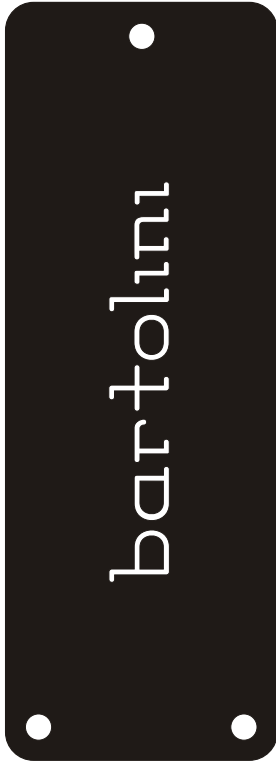

# BD

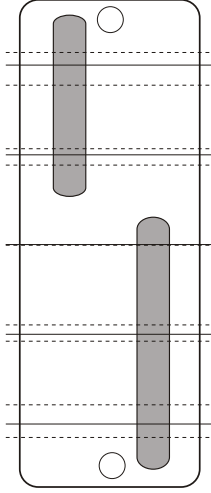

xxBD5M - 5 st. split coil - deeper

xxBD5T - 5 st. split coil - brighter

xxBD quad coil splittable pickups will work with string widths from 64mm to 80mm if the fingerboard radius is greater than 14 inches

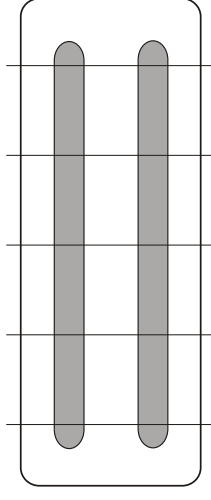

72BD5C - 72mm 5 st. dual coil - deeper

72BD5CX - 72mm 5 st. dual coil - brighter

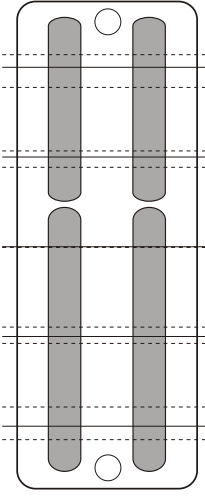

xxBD5C - 5 st. quad coil splittable - deeper

xxBD5CX - 5 st. quad coil splittable - brighter





# M4

same shape as EMG40

xxM4 pickups will work with string widths from 64mm to 80mm if the fingerboard radius is greater than 14 inches (360mm)

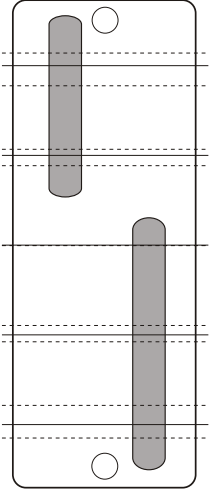

xxM45M - 5 st. split coil - deeper  
xxM45T - 5 st. split coil - brighter

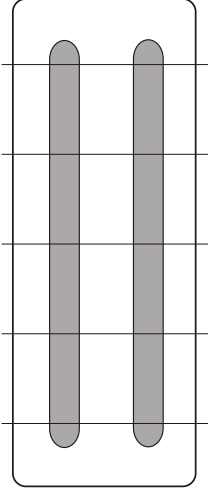

72M45C - 72mm 5 st. dual coil - deeper  
72M45CX - 72mm 5 st. dual coil - brighter

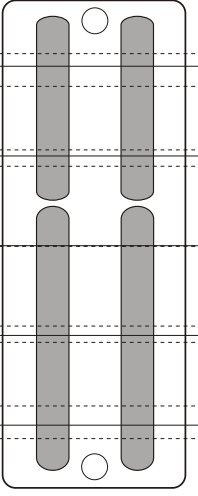

xxM45C - 5 st. quad coil splittable - deeper  
xxM45CX - 5 st. quad coil splittable - brighter

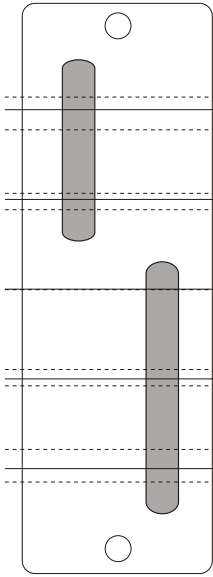

xxM55M - 5 st. split coil - deeper  
xxM55T - 5 st. split coil - brighter

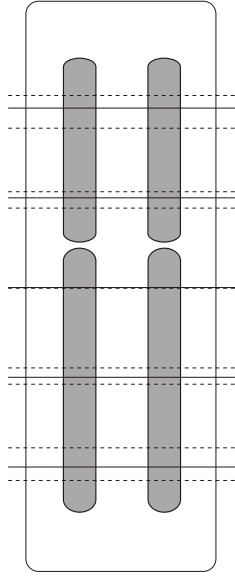

xxM55C - 5 st. quad coil splittable - deeper  
xxM55CX - 5 st. quad coil splittable - brighter

# M5

same shape as EMG45

xxM5 pickups will work with string widths from 64mm to 80mm if the fingerboard radius is greater than 14 inches (360mm)

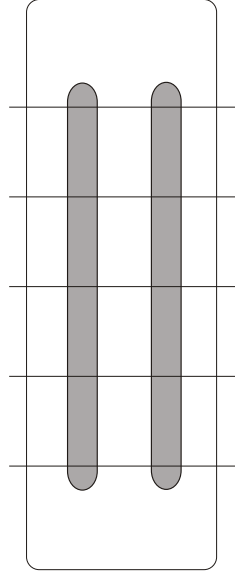
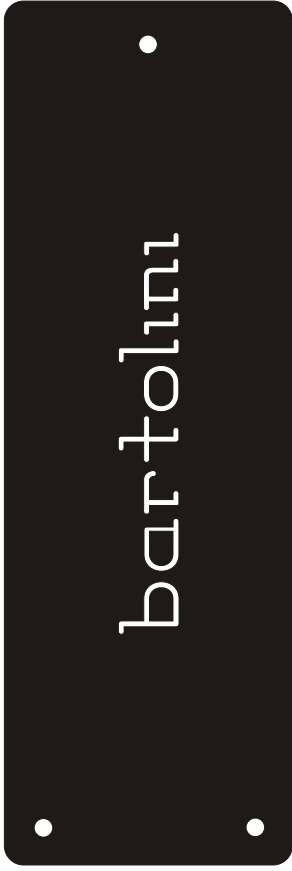

72M55C - 72mm 5 st. dual coil - deeper  
72M55CX - 72mm 5 st. dual coil - brighter



# X4

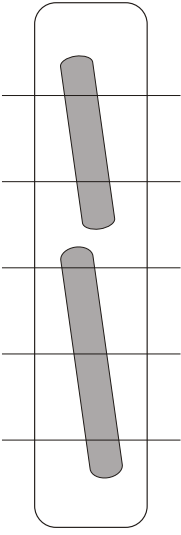

X45J - split coil - deeper tone  
X45K - split coil - brighter tone  
64mm to 75mm string width

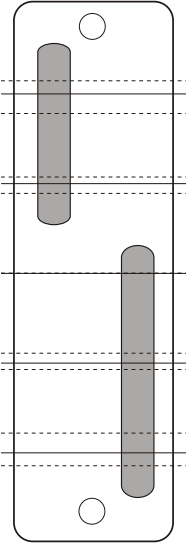

xxP25M - 5 st. split coil - deeper  
xxP25T - 5 st. split coil - brighter

# P2

xxP2 pickups will work with string widths from 68mm to 80mm if the fingerboard radius is greater than 14 inches (360mm)

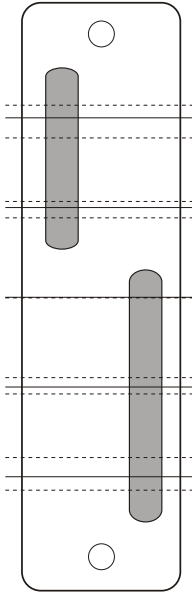

xxP45M - 5 st. split coil - deeper  
xxP45T - 5 st. split coil - brighter

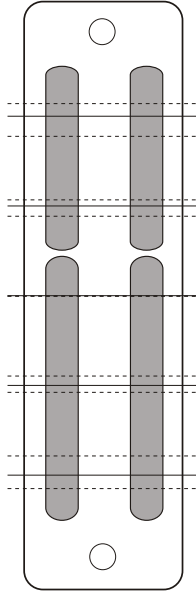

xxP45C - 5 st. quad coil splittable - deeper  
xxP45CX - 5 st. quad coil splittable - brighter

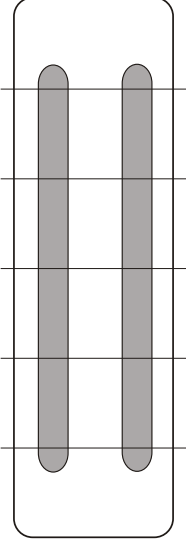

72P25C - 72mm 5 st. dual coil - deeper  
72P25CX - 72mm 5 st. dual coil - brighter

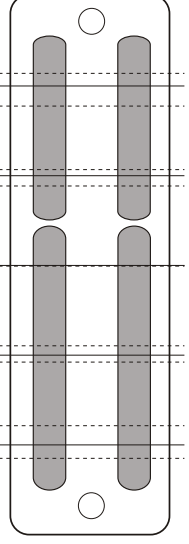

xxP25C - 5 st. quad coil splittable - deeper  
xxP25CX - 5 st. quad coil splittable - brighter

# P4

xxP4 pickups will work with string widths from 68mm to 80mm if the fingerboard radius is greater than 14 inches (360mm)

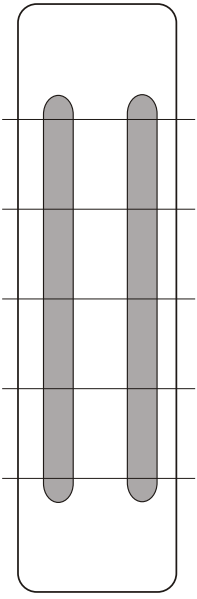

72P45C - 72mm 5 st. dual coil - deeper  
72P45CX - 72mm 5 st. dual coil - brighter

# 6 string soapbars

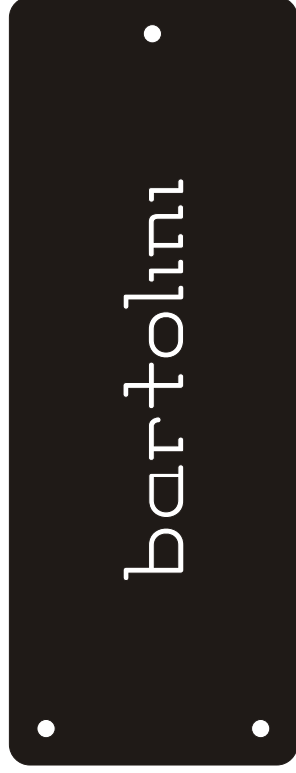

xxM46 pickups will work with string widths from 72mm

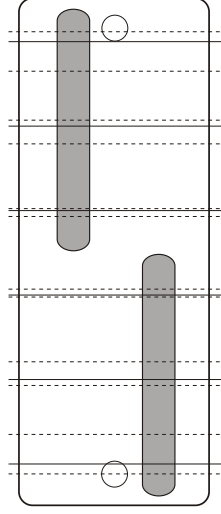

xxM46M - 6 st. split coil - deeper  
xxM46T - 6 st. split coil - brighter

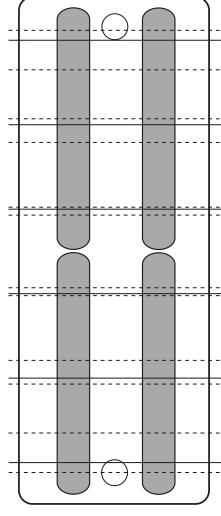

xxM46C - 6 st. quad coil splittable - deeper  
xxM46CX - 6 st. quad coil splittable - brighter

## M4

same shape as EMG40

to 88mm if the fingerboard radius is greater than 14 inches (360 mm)

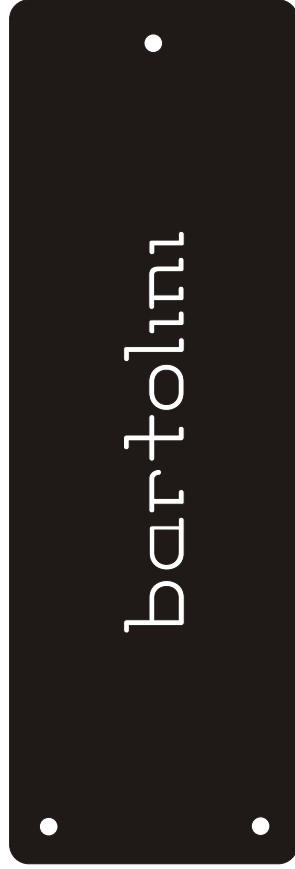

bartolini

## M5

same shape as EMG45

xxM5 pickups will work with string widths from 72mm to 95mm if the fingerboard radius is greater than 14 inches (360mm)

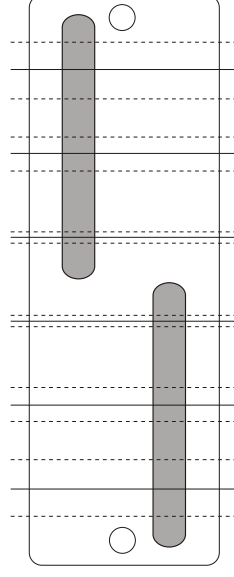

xxM56M - 6 st. split coil - deeper  
xxM56T - 6 st. split coil - brighter

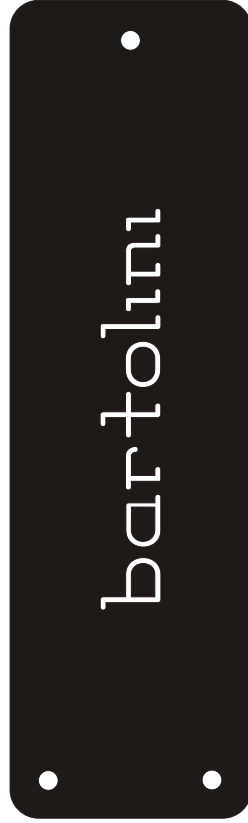

bartolini

## P2

xxP26 pickups will work with string widths from 74mm to 90mm if the fingerboard radius is greater than 14 inches (360 mm)

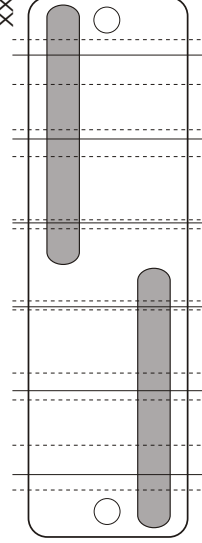

xxP26M - 6 st. split coil - deeper  
xxP26T - 6 st. split coil - brighter

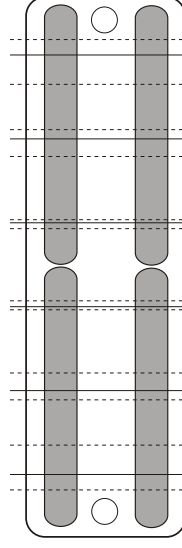

xxP26C - 6 st. quad coil splittable - deeper  
xxP26CX - 6 st. quad coil splittable - brighter

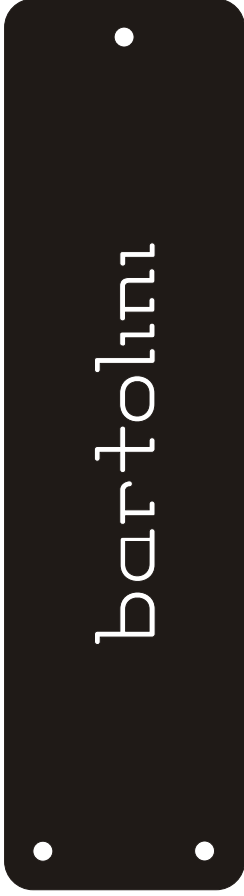

# P4

xxP4 pickups will work with string widths from 74mm to 90mm if the fingerboard radius is greater than 14 inches (360mm)

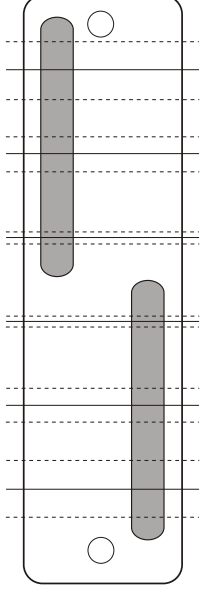

xxP46M - 6 st. split coil - deeper  
xxP46T - 6 st. split coil - brighter

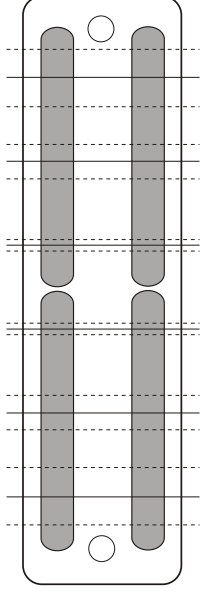

xxP46C - 6 st. quad coil splittable - deeper  
xxP46CX - 6 st. quad coil splittable - brighter



# G6

G6 shape pickups are available in string widths of 96mm and 100mm

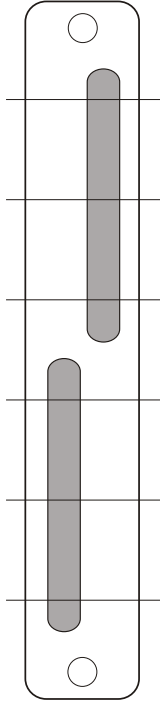

96G6M - 6 st. split coil - deeper  
96G6T - 6 st. split coil - brighter  
100G6M - 6 st. split coil - deeper  
100G6T - 6 st. split coil - brighter

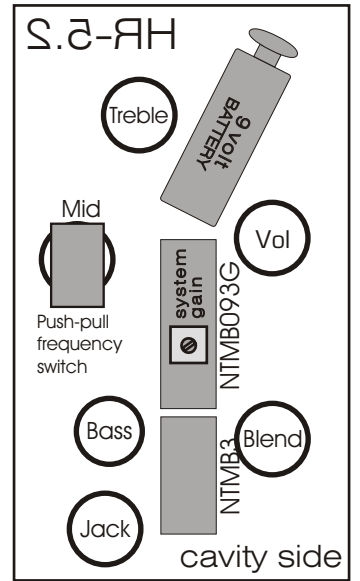
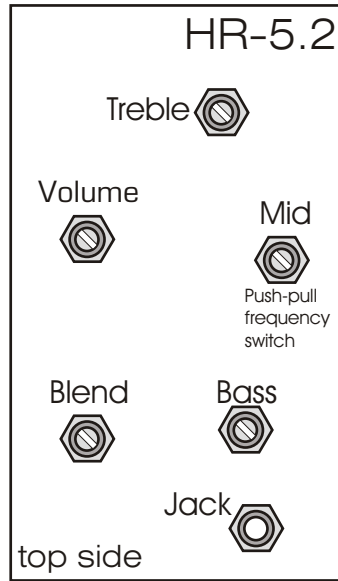
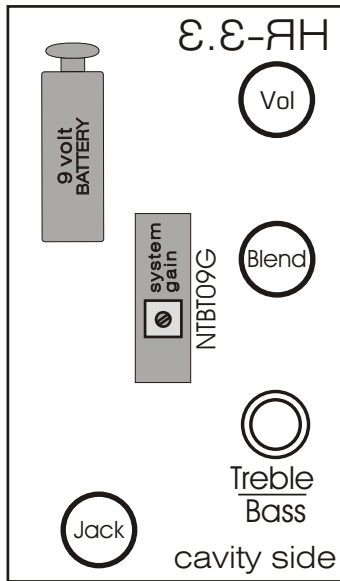
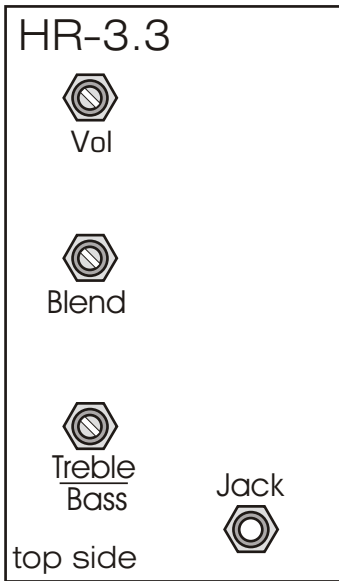
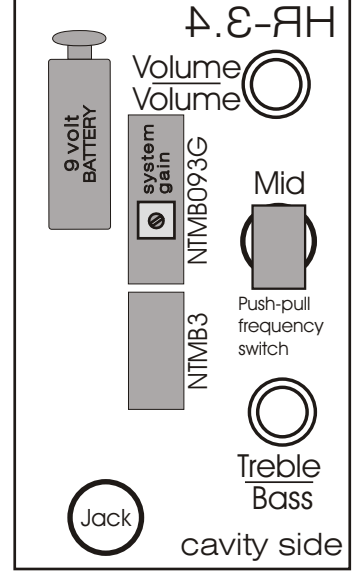
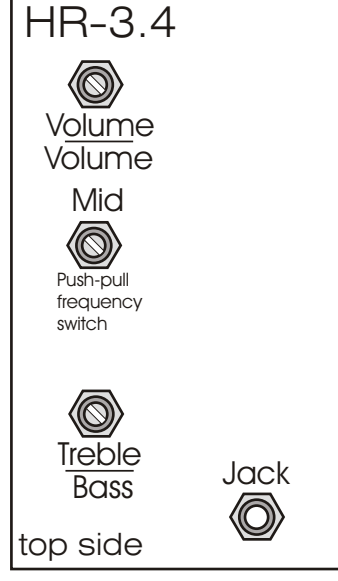
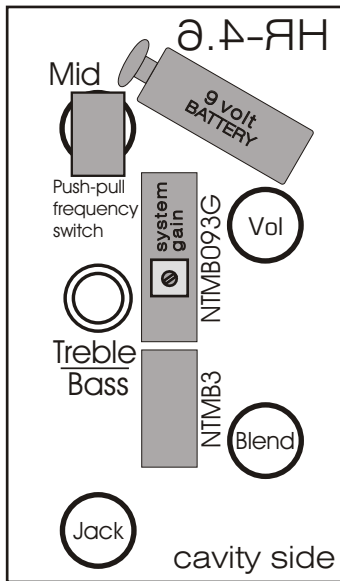
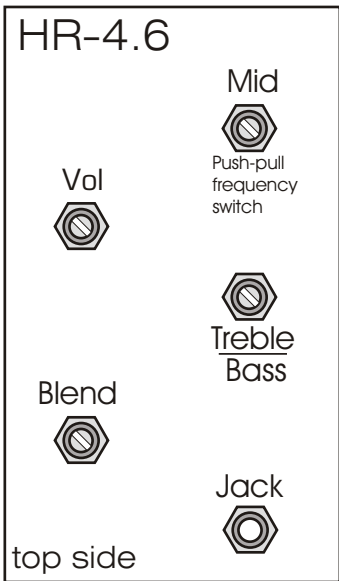
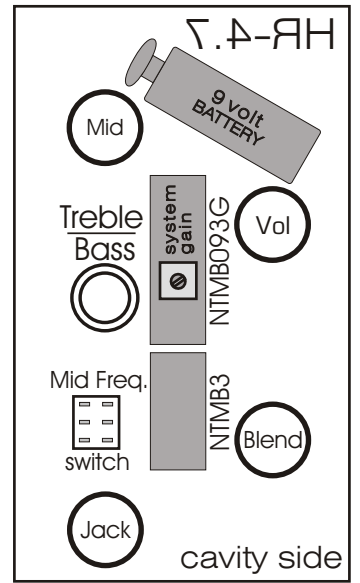
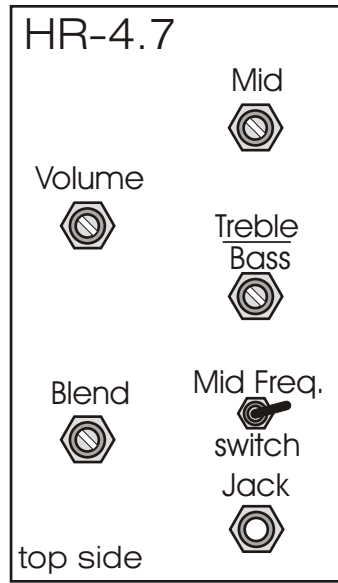
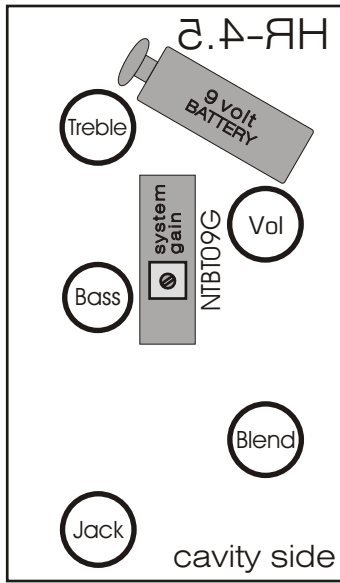
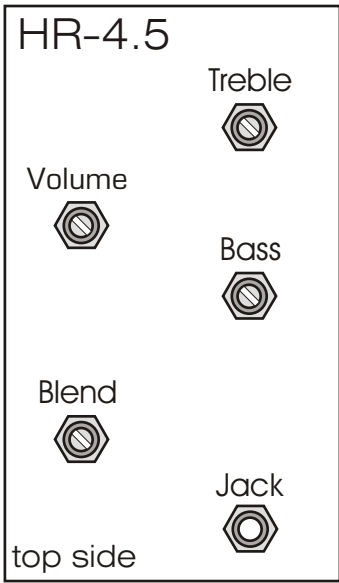

# PICKUP OUTPUT LEVEL COMPARISON CHART

