

The TCT is a tone control module designed for electric guitars, basses and other electronic musical instruments. It yields a very wide range of boost or attenuation of the Bass, Midrange and Treble regions of the musical instrument spectrum. Its tonal range is at least equal to that of the older Fender amplifiers with Bass, Treble and Presence (low midrange) controls.

The TCT is designed for the input levels expectable from medium output passive magnetic pickups (less than 70 mV on the output level charts in our catalog). Higher output level pickups such as active pickups or some of our 4 string bass humbuckers may cause distortion of the input and/or output stages of the TCT (depending on the boost levels chosen). Active pickups can be attenuated easily without changing their tone quality. The TCT-B (lower gain version of the TCT) should be used for high output passive pickups. For pickups with low output levels (less than 30 mV on the output level charts in our catalog) the TCT-H should be used. Wiring diagram 4 shows how to increase the overall gain of the TCT to compensate for low output pickups. But using the TCT-H will yield higher built-in gain at lower noise level.

All TCT's are internally shielded for very low hum and noise levels and use a single 9V battery with very low battery drain. Battery life is more than 2 months of continuous use from most alkaline batteries.

Input impedance 320 K-ohms
Output impedance 60 K-ohms

Using a 25K-ohm Volume control (wirings 1&2) lowers the output level (but not the headroom) by 6 dB to approx. 1.25 Volts r.m.s. undistorted signal. This level is quite sufficient to drive modern bass amplifiers to full power easily. Wirings 1&2 are the most common wirings for the TCT family modules.

For maximum output use a 250K-ohm Volume control (wirings 3, 5 &6) or no Master Volume control (wiring 4). A 250K-ohm Volume control is necessary when an Active/Passive switch is used.

The cd50kM Mid control and MCT Mid Boost Modules enhance the response of the TCT by adding a low midrange peak and extended high frequency shelf to the response shown in the top graph at right. From center click to minimum the Mid control cuts low mids at 400 Hz as shown in the graph. From center click to maximum the Mid control adds both low mid boost and upper treble definition (not shown).

Mid Boost	mid peak	high frequency shelf
MCT-250	250 Hz	2KHz to 15KHz
MCT-375	375 Hz	2KHz to 15KHz
MCT-500	500 Hz	2KHz to 15KHz

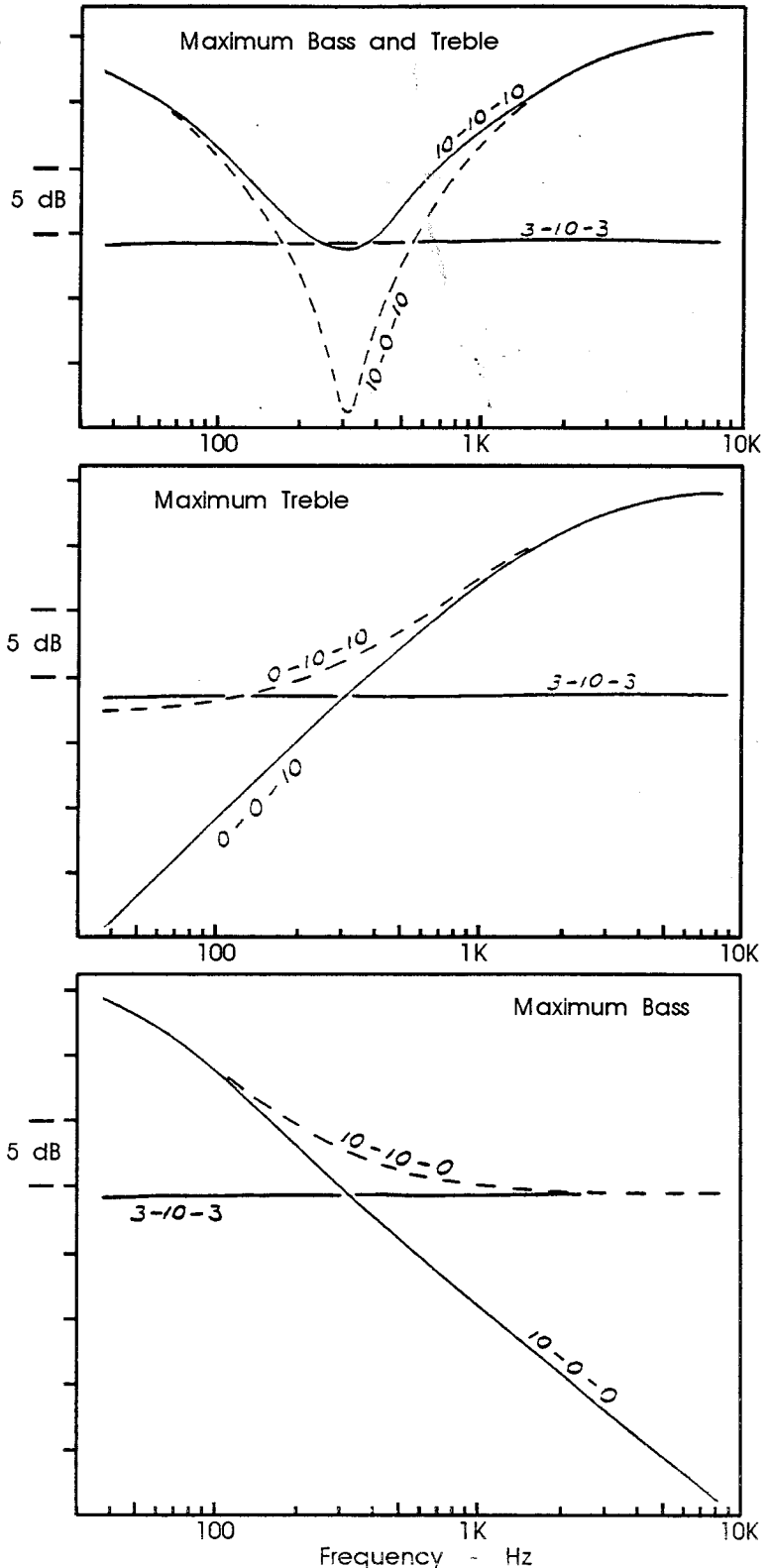

TCT in 2 pickup instrument with Volume, Blend, Treble, Mid & Bass Controls with Mid Boost Module (1)

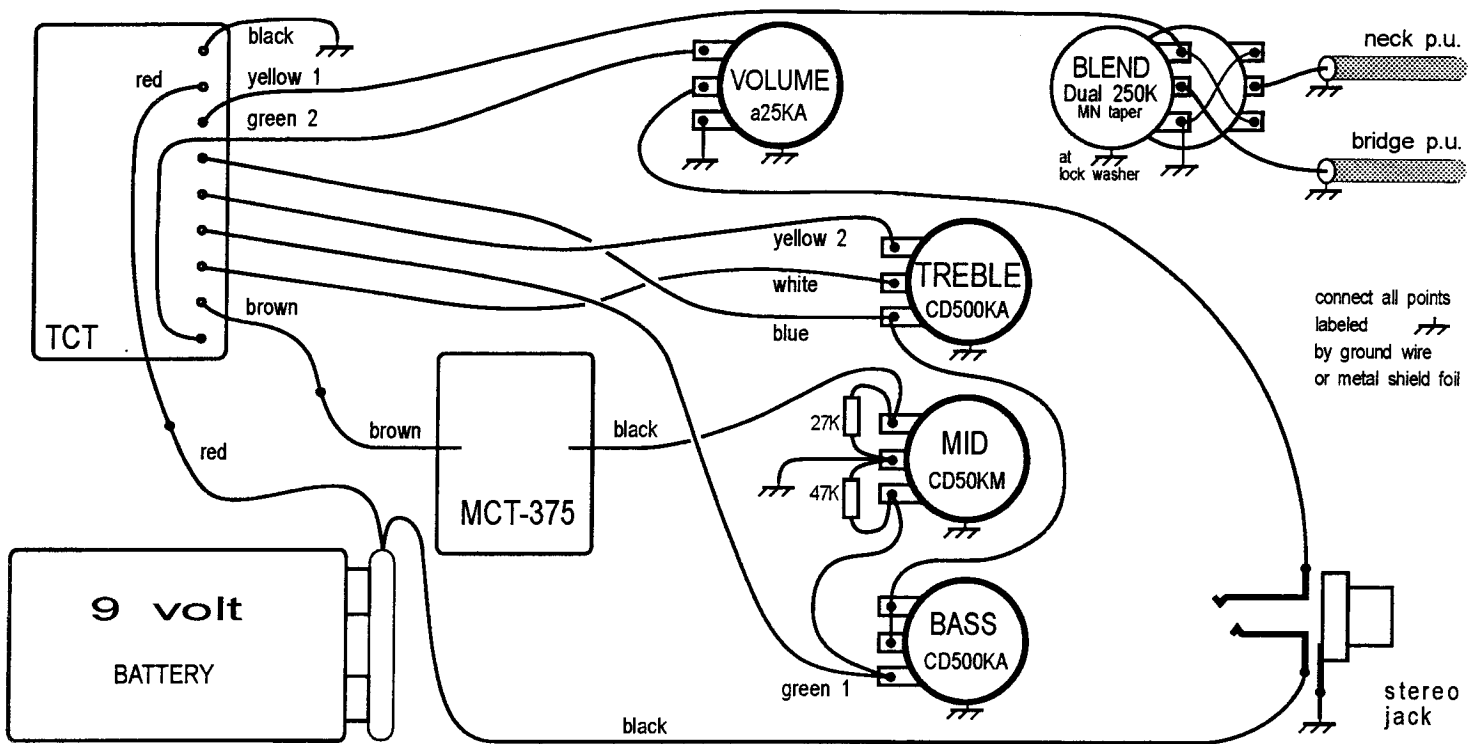

TCT in 2 pickup instrument with Volume, Blend, Treble/Bass (Dual Concentric) and Mid Controls with Mid Boost Module (2)

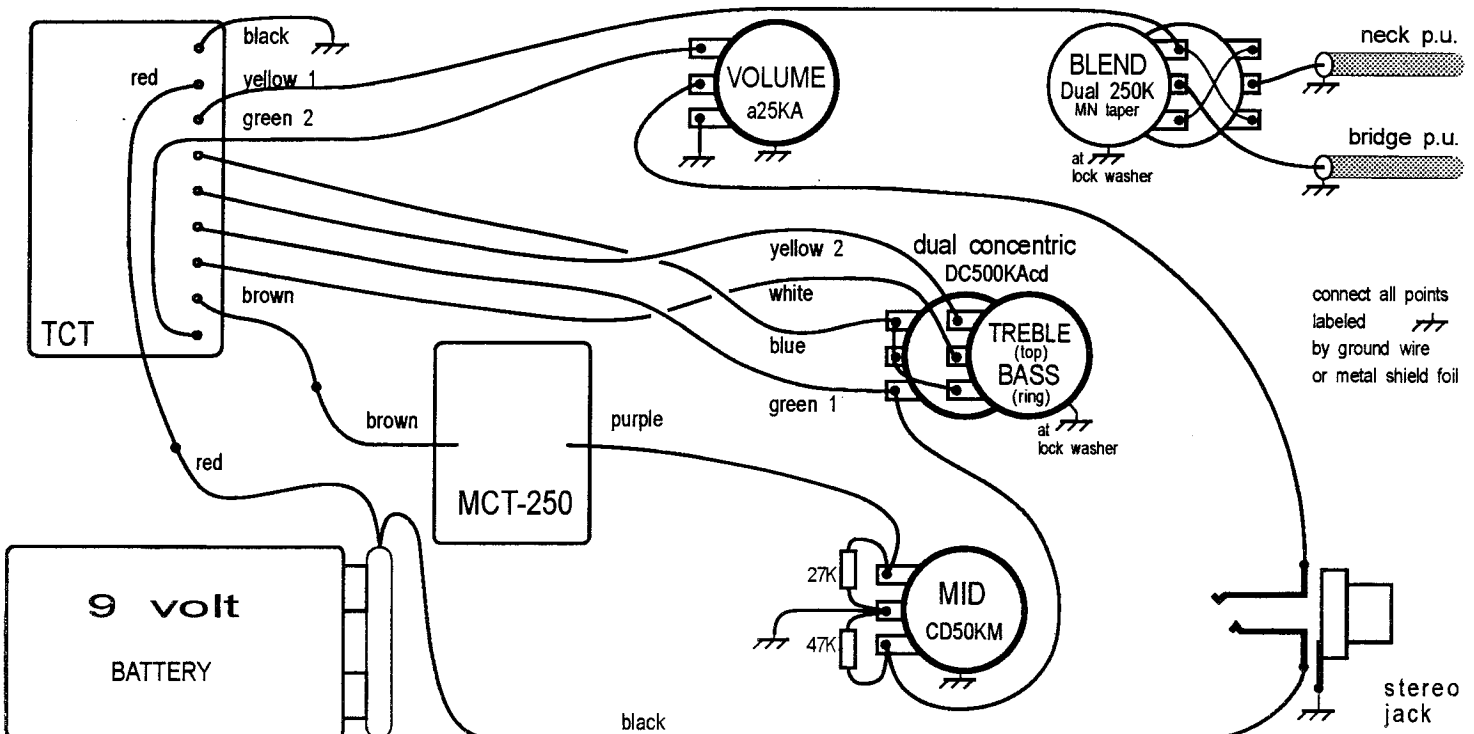

TCT in 2 pickup instrument with Volume, Blend, Treble and Bass Controls with Active/Passive Switch & Mid Boost Module (Mid Boost/Cut by mini trim pot.) (3)

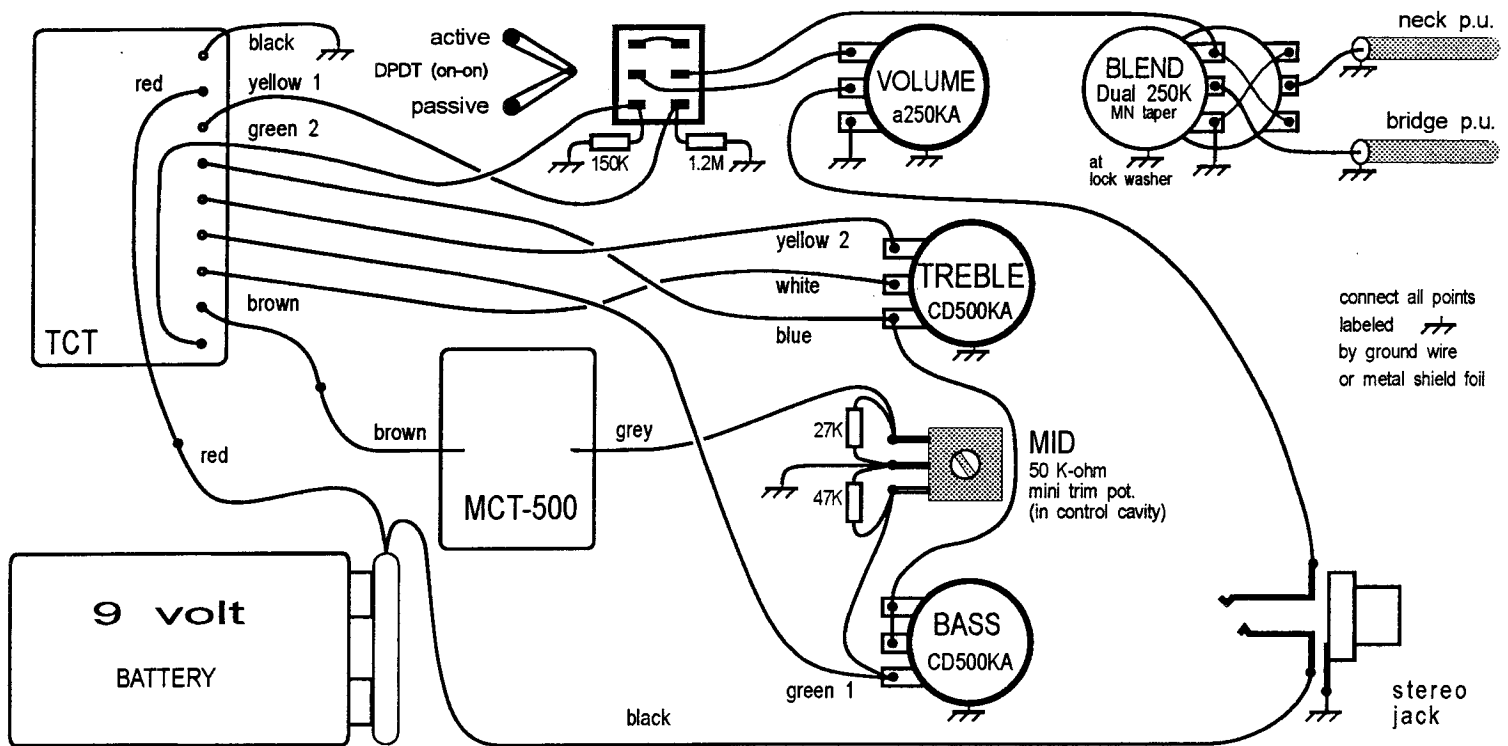

TCT in 2 pickup instrument with 2 Volumes and Treble/Bass (Dual Concentric) Controls with Mid Cut control and Full Spectrum Boost (4)

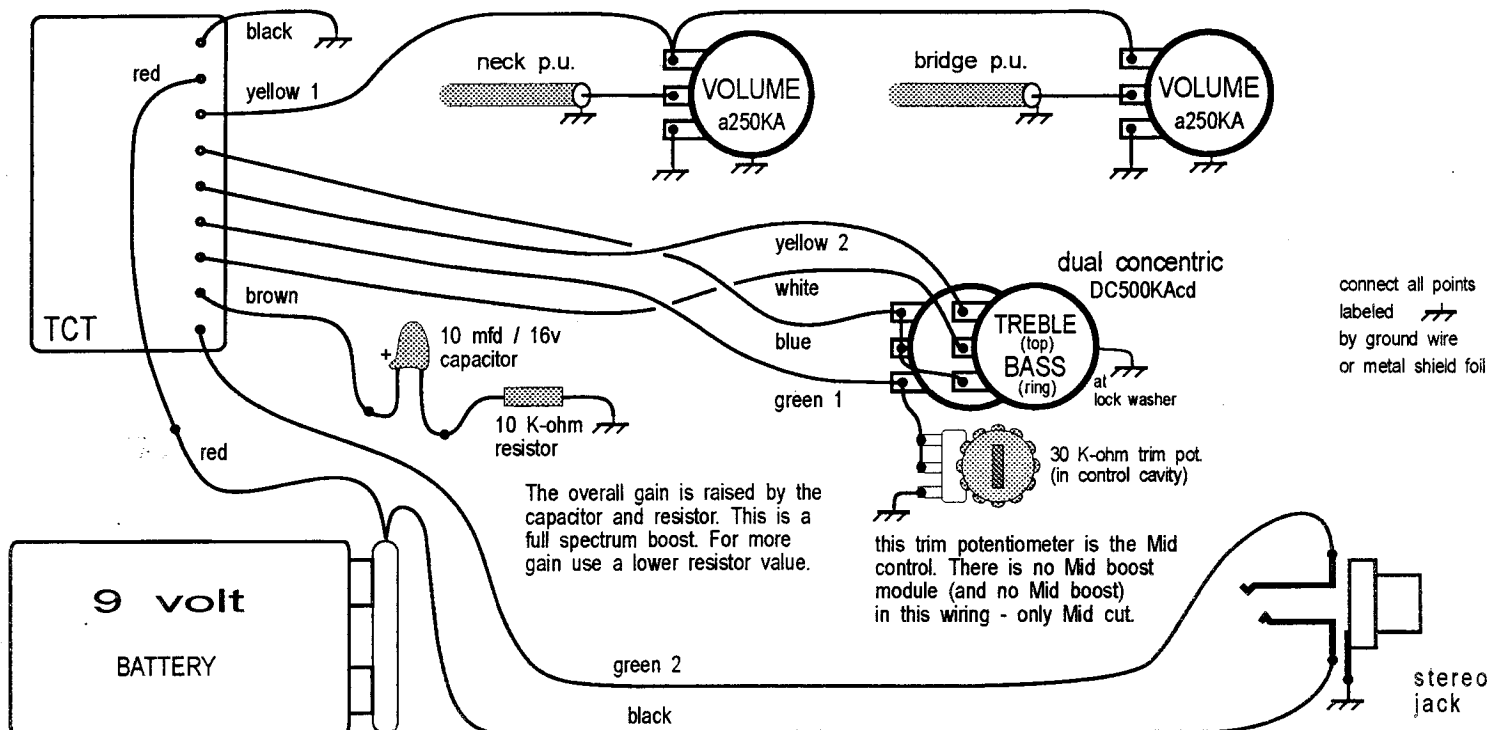

TCT in 2 pickup instrument with Volume, Blend, Treble, Mid and Bass Controls with Active/Passive Switch and Mid Boost Module (5)

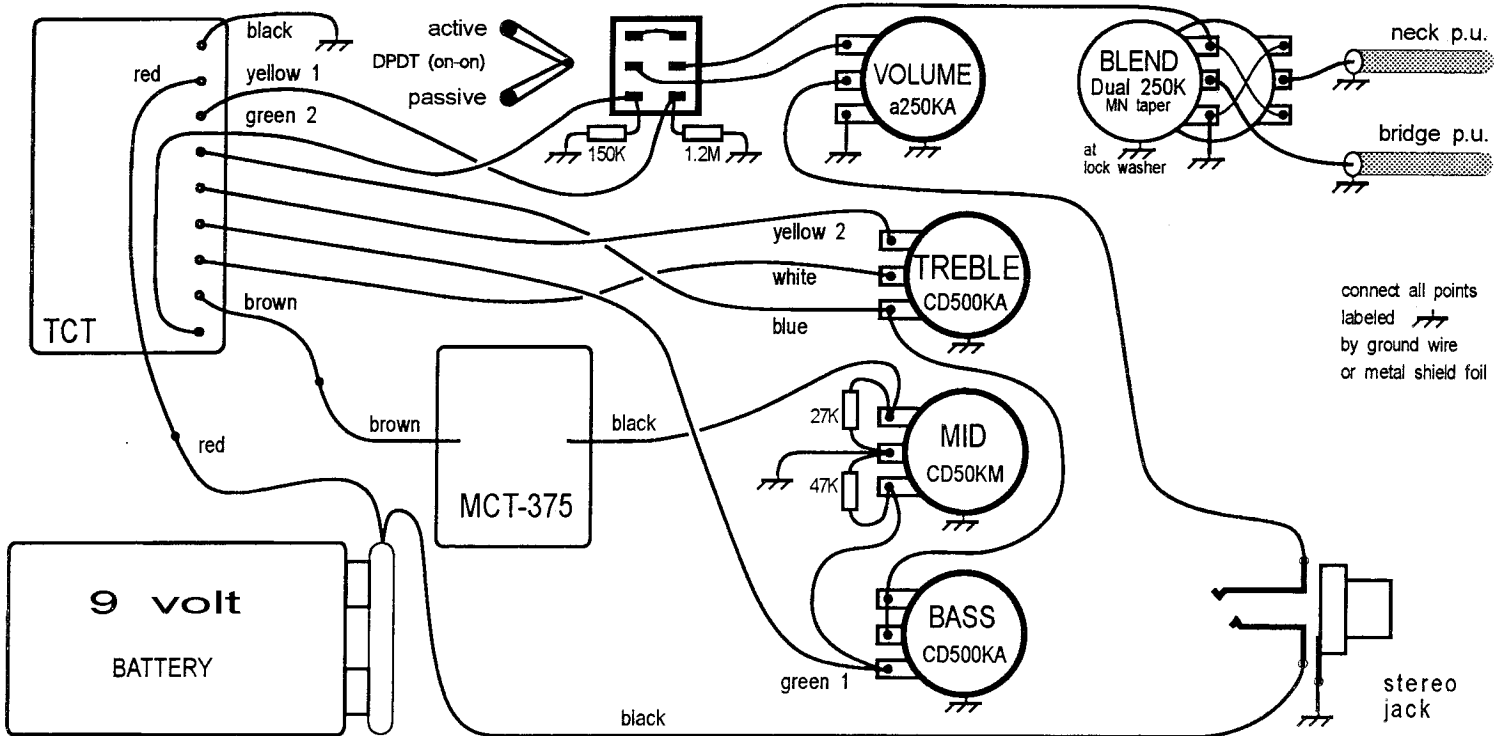

TCT in 2 pickup instrument with Volume, Blend, Treble/Bass (Dual Concentric) and Mid Controls with Active/Passive Switch and Mid Boost Module (6)

