

The four separate buffers in the TQB Quad Buffer can reduce electronic noise levels in instruments with passive pickups and some of our on-board preamps. Each buffer in the TQB is a low noise amplifier with a gain of 1, an input impedance of 270 K-ohms and an output impedance of less than 10 K-ohms. This low output impedance allows the TQB to drive 25K-ohm Volume or Blend controls very easily.

4 Channel (quadraphonic) Buffer

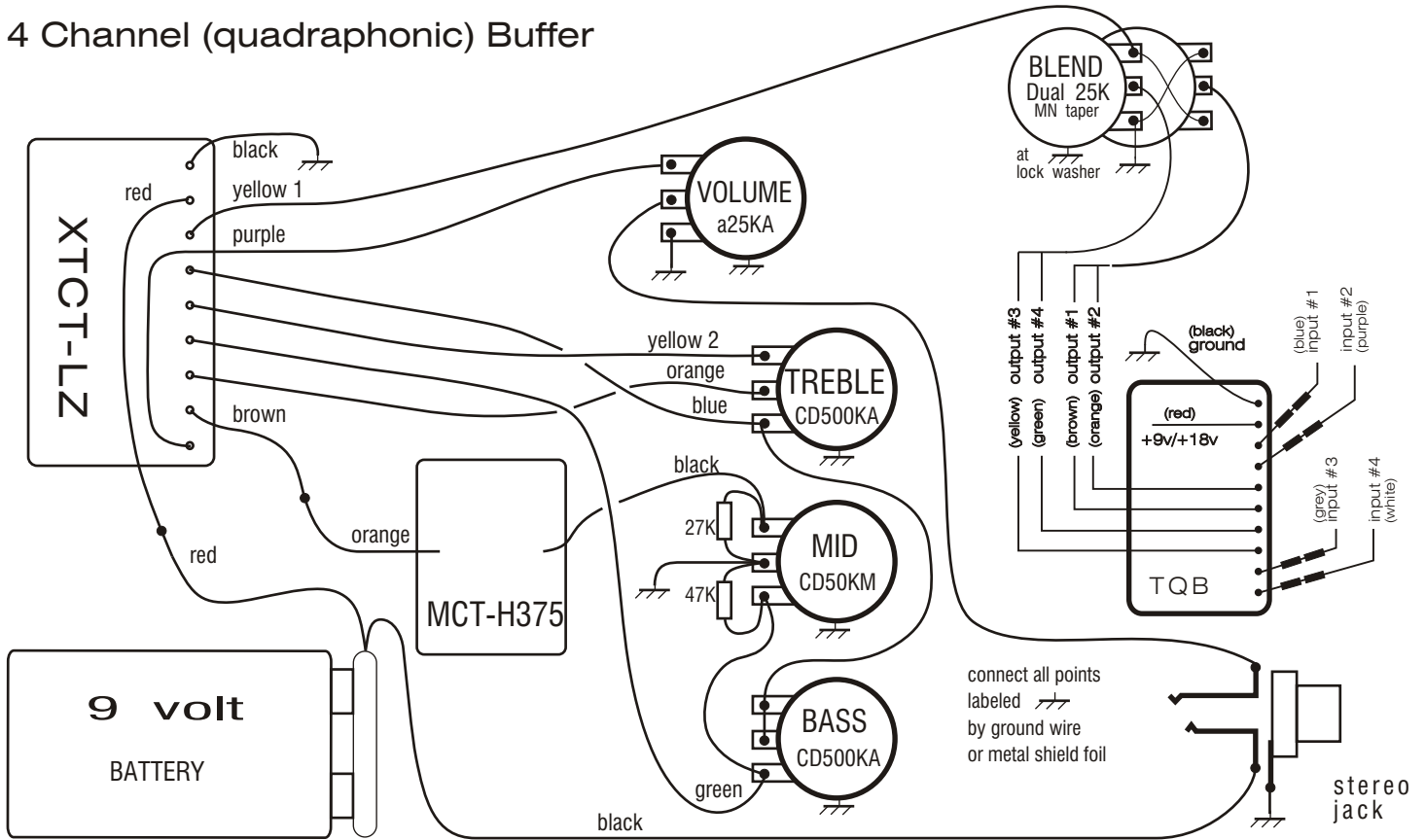

The four separate buffers in the TQB Quad Buffer can reduce electronic noise levels in instruments with passive pickups and some of our on-board preamps. Each buffer in the TQB is a low noise amplifier with a gain of 1, an input impedance of 270 K-ohms and an output impedance of less than 10 K-ohms. This low output impedance allows the TQB to drive 25K-ohm Volume or Blend controls very easily.

This configuration was used in many instruments by Michael Tobias in the mid-late 80's.

The inputs were:

- Input 1: neck coil of neck pickup
- Input 2: bridge coil of neck pickup
- Input 3: neck coil of bridge pickup
- Input 4: bridge coil of bridge pickup

The tone quality was similar to that of the coils in parallel but with higher definition and lower noise.